

No.	GBR/CAA Clubman Schedule	K
1	Rectangular Take-off Sequence	2
2	Two Inside Loops	3
3	Immelman Turn	2
4	One Outside Loop	2
5	Split S	2
6	Cuban Eight with No Rolls	3
7	Stall Turn	1
8	Slow Roll	3
9	Half Square Loop, ½ Roll on Exit	2
10	Two Turn Spin	3
11	Rectangular Landing Sequence	2

Max. Score = 250

Promotion = 150 (60%)

No.	GBR/CAA Clubman Schedule	K
1	Rectangular Take-off Sequence	2
2	Two Inside Loops	3
3	Immelman Turn	2
4	One Outside Loop	2
5	Split S	2
6	Cuban Eight with No Rolls	3
7	Stall Turn	1
8	Slow Roll	3
9	Half Square Loop, ½ Roll on Exit	2
10	Two Turn Spin	3
11	Rectangular Landing Sequence	2

Max. Score = 250

Promotion = 150 (60%)

No.	GBR/CAA Clubman Schedule	K
1	Rectangular Take-off Sequence	2
2	Two Inside Loops	3
3	Immelman Turn	2
4	One Outside Loop	2
5	Split S	2
6	Cuban Eight with No Rolls	3
7	Stall Turn	1
8	Slow Roll	3
9	Half Square Loop, ½ Roll on Exit	2
10	Two Turn Spin	3
11	Rectangular Landing Sequence	2

Max. Score = 230

Promotion = 150 (60%)

No.	GBR/CAA Clubman Schedule	K
1	Rectangular Take-off Sequence	2
2	Two Inside Loops	3
3	Immelman Turn	2
4	One Outside Loop	2
5	Split S	2
6	Cuban Eight with No Rolls	3
7	Stall Turn	1
8	Slow Roll	3
9	Half Square Loop, ½ Roll on Exit	2
10	Two Turn Spin	3
11	Rectangular Landing Sequence	2

Max. Score = 250

Promotion = 150 (60%)

GBR/CAA Clubman Schedule

Drawn by: Alan Simmonds
Dec. 2002

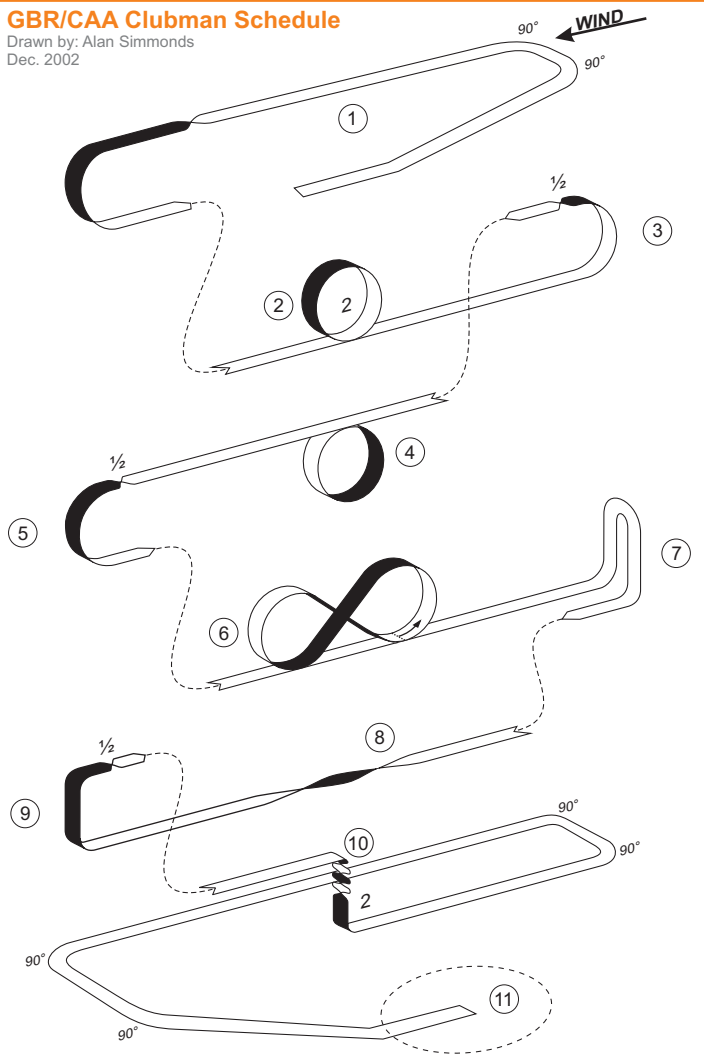

GBR/CAA Clubman Schedule

Drawn by: Alan Simmonds
Dec. 2002

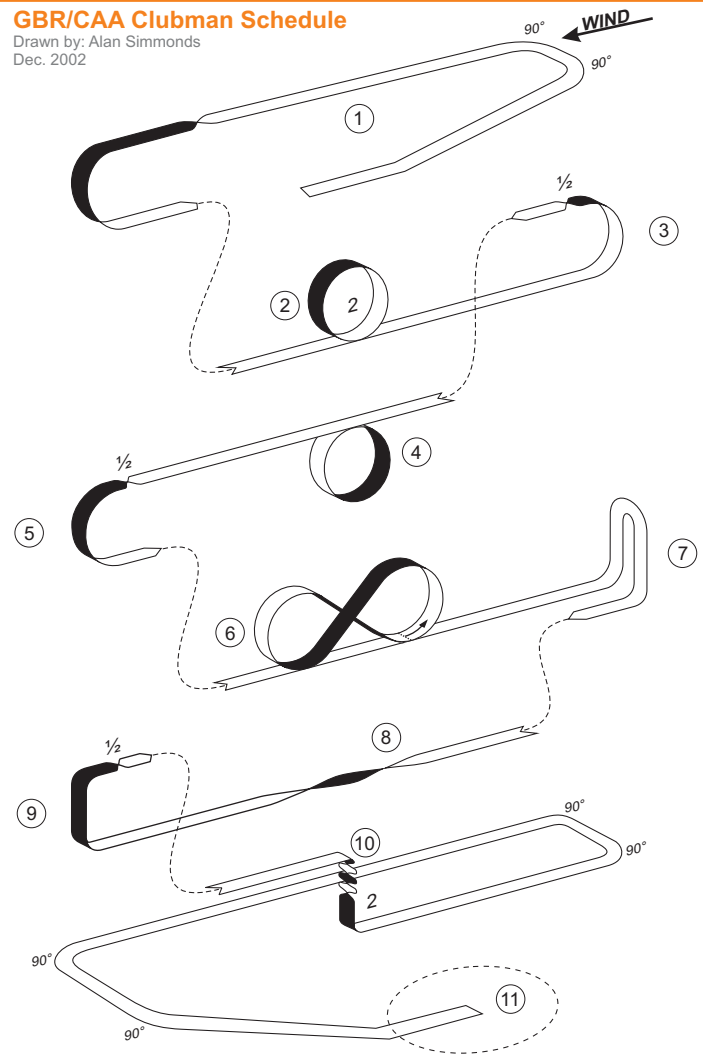

GBR/CAA Clubman Schedule

Drawn by: Alan Simmonds
Dec. 2002

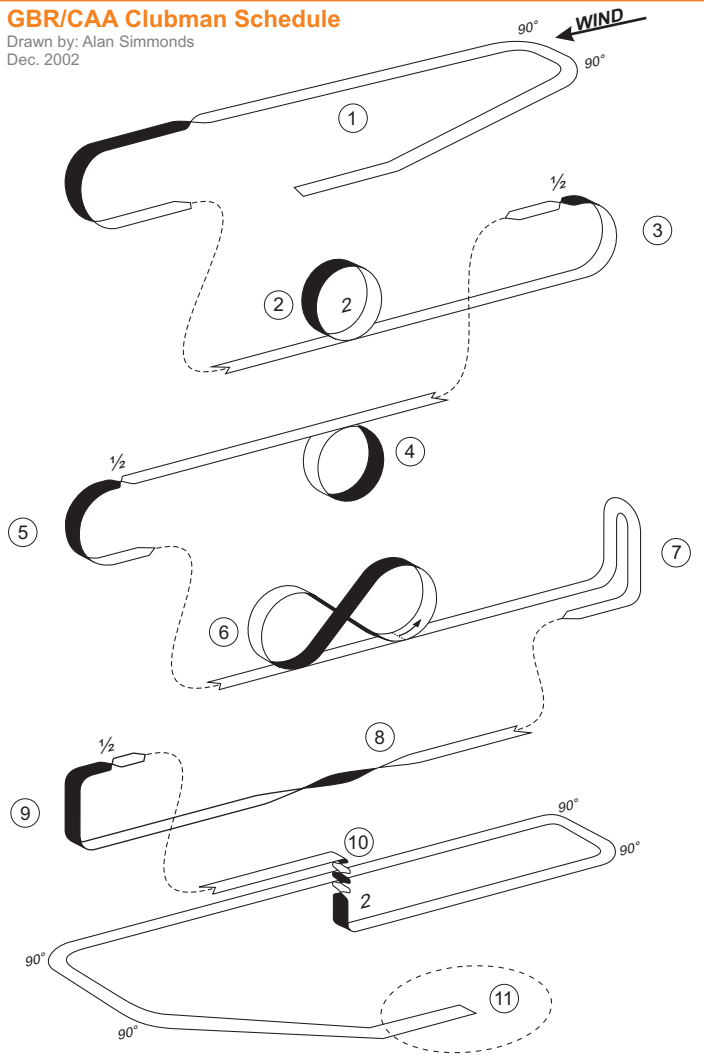

GBR/CAA Clubman Schedule

Drawn by: Alan Simmonds
Dec. 2002

